

**UNIDRIVE SP SIZE 0 (0.37 to 1.5 kW)
DIGITAX ST (1.1A to 8A)
ELECTROMAGNETIC COMPATIBILITY DATA**

PRODUCT SP0201 – 0205, SP0401 – 0405, DST1201 – 1204, DST1401 - 1405

General note on EMC data

The information given in this data sheet is derived from tests and calculations on sample products. It is provided to assist in the correct application of the product, and is believed to correctly reflect the behaviour of the product when operated in accordance with the instructions. The provision of this data does not form part of any contract or undertaking. Where a statement of conformity is made with a specific standard, the company takes all reasonable measures to ensure that its products are in conformance. Where specific values are given these are subject to normal engineering variations between samples of the same product. They may also be affected by the operating environment and details of the installation arrangement

Note on issue 2 data sheet

Conducted emission data on page 7 amended to give some 16kHz data, and to correct some cable length limits.

IMMUNITY

The drive complies with the following international and European harmonised standards for immunity:

Standard	Type of immunity	Test specification	Application	Level
EN 61000-4-2 IEC 61000-4-2	Electrostatic discharge	6kV contact discharge 8kV air discharge	Module enclosure	Level 3 (industrial)
EN 61000-4-3 IEC 61000-4-3	Radio frequency radiated field	80% AM (1kHz) modulation Levels prior to modulation: 10V/m 80 - 1000MHz 3V/m 1.4 – 2.0GHz 1V/m 2.0 – 2.7GHz	Module enclosure	Level 3 (industrial)
EN 61000-4-4 IEC 61000-4-4	Fast transient burst	5/50ns 2kV transient at 5kHz repetition frequency via coupling clamp	Control lines	Level 4 (industrial harsh)
		5/50ns 2kV transient at 5kHz repetition frequency by direct injection	Power lines	Level 3 (industrial)
EN 61000-4-5 IEC 61000-4-5	Surges	Common mode 4kV 1.2/50µs waveshape	AC supply lines: line to earth	Level 4
		Differential mode 2kV	AC supply lines: line to line	Level 3
		Common mode 1kV	Control lines ¹	
EN 61000-4-6 IEC 61000-4-6	Conducted radio frequency	10V prior to modulation 0.15 - 80MHz 80% AM (1kHz) modulation	Control and power lines	Level 3 (industrial)
EN 61000-4-11 IEC 61000-4-11	Voltage dips, short interruptions & variations	All durations	AC supply lines	
EN 61000-4-8 IEC 61000-4-8	Power frequency magnetic field	1700 A/m r.m.s. 2400 A/m peak (2.1mT peak 3mT r.m.s.) continuous at 50Hz	Module enclosure	Exceeds level 5
EN 61000-6-1 IEC 61000-6-1	Generic immunity standard for the residential, commercial and light - industrial environment			Complies
EN 61000-6-2 ² IEC 61000-6-2	Generic immunity standard for the industrial environment			Complies
EN 61800-3 IEC 61800-3	Product standard for adjustable speed power drive systems (immunity requirements)		Meets immunity requirements for first and second environments	

¹ Applies to ports where connections may exceed 30m length. Special provisions may be required in some cases – see additional information below.

² Supersedes EN 50082-2

Unless stated otherwise, immunity is achieved without any additional measures such as filters or suppressors. To ensure correct operation the wiring guidelines specified in the User Guide must be carefully adhered to. All inductive components such as relays, contactors, electromagnetic brakes etc. associated with the drive must be fitted with appropriate suppression, otherwise the immunity capability of the drive may be exceeded.

Surge immunity of control circuits – long cables and connections outside a building

The input/output ports for the control circuits are designed for general use within machines and small systems without any special precautions.

These circuits meet the requirements of EN 61000-6-2 (1kV surge) provided the 0V connection is not earthed, i.e. in the common mode. Generally they cannot withstand the surge directly between the control lines and the 0V connection, i.e. in the series mode.

The surge test simulates the effect of lightning or severe electrical faults in a physically extended electrical system, where high differential transient voltages may appear between different points in the grounding system. This is a particular risk where the circuits extend outside the protection of a building, or if the grounding system in a large building is not well bonded.

In applications where control circuits may be exposed to high-energy voltage surges, some special measures may be required to prevent malfunction or damage. As a general rule, if the circuits are to pass outside the building where the drive is located, or if wiring runs within a building exceed 30m, some additional precautions are advisable. One of the following techniques should be used:

1. Galvanic isolation, i.e. do not connect the control 0V terminal to ground. Avoid open loops in the control wiring, i.e. ensure every control wire is accompanied by its associated return (0V) wire.
2. Screened cable with additional power ground bonding. If isolation at one end is not acceptable, the cable screen may be connected to ground at both ends, but in addition the ground conductors at both ends of the cable must be bonded together by a power ground cable (equipotential bonding cable) with cross-sectional area of at least 10mm², or 10 times the area of the signal cable screen, or to suit the electrical safety requirements of the plant. This ensures that fault or surge current passes mainly through the ground cable and not in the signal cable screen. If the building or plant has a well-designed common bonded network this precaution is not necessary.
3. Additional over-voltage suppression – for the analogue and digital inputs and outputs, a zener diode network or a commercially available surge suppressor may be connected in parallel with the input circuit as shown in Figures 1 and 2.

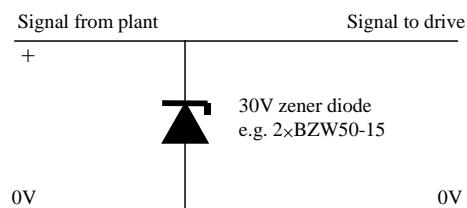

Figure 1: surge suppression for digital and unipolar analogue inputs and outputs

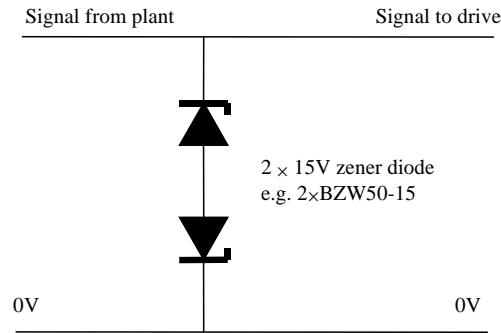

Figure 2: surge suppression for bipolar analogue inputs and outputs

Surge suppression devices are available as rail-mounting modules, e.g. from Phoenix Contact GmbH:

Unipolar	TT-UKK5-D/24 DC
Bipolar	TT-UKK5-D/24 AC

These devices are not suitable for encoder signals or fast digital data networks because the capacitance of the diodes adversely affects the signal. Most encoders have galvanic isolation of the signal circuit from the motor frame, in which case no precautions are required. For data networks, follow the specific recommendations for the particular network.

EMISSION

Emission occurs over a wide range of frequencies. The effects are divided into three main categories:

- Low frequency effects, such as supply harmonics and notching.
- High frequency emission below 30MHz where emission is predominantly by conduction.
- High frequency emission above 30MHz where emission is predominantly by radiation.

SUPPLY VOLTAGE NOTCHING

Because of the use of uncontrolled input rectifiers these drives cause no significant notching of the supply voltage.

SUPPLY HARMONICS

The input current contains harmonics of the supply frequency. Since the drive input has a low impedance, the harmonic current levels are affected to some extent by the supply impedance (fault current level). The table shows the levels calculated with fault level of 5kA at 230V/400V 50Hz. This would be typical of a light industrial installation. This meets and exceeds the requirements of IEC 61800-3. For installations where the fault level is lower, so that the harmonic current is more critical, the harmonic current will also be lower than that shown. For illustration in the case of single phase supplies data is also given for a "residential" type of supply with an impedance of $(0.4+j0.25)\Omega$ (according to IEC 60725).

Note that the r.m.s. current in these tables may be lower than the maximum specified in the installation guide, since the latter is a worst-case value provided for safety reasons which takes account of permitted supply voltage imbalance.

The input power determines the input current, and this depends upon the motor power factor and efficiency. For the SP0 unit, a standard Eff2 induction motor has been assumed. For the Digitax ST unit, where the motor is rated in terms of current, the data applies to the recommended Control Techniques Unimotor, which is assumed to be running at base speed, giving a power factor of unity.

The supply voltage for the calculation was 230V/400V 50Hz. The harmonic percentages do not change substantially for other voltages and frequencies within the drive specification.

For balanced sinusoidal supplies, all even and triplen harmonics are absent.

Single phase 230V supply

SP0 series

Supply with 5kA fault level:

Model no. SP020-	Motor power (kW)	R.m.s. current (A)	Fundamental current (A)	THD (%)*	Harmonic order, magnitude as % fundamental											
					3	5	7	9	11	13	15	17	19	21	23	25
1	0.37	5.4	2.3	211.2	97.6	92.8	86.1	77.7	68.1	57.8	47.3	37.1	27.6	19.3	12.3	7.0
2	0.55	7.9	3.6	193.1	96.8	90.6	81.8	71.2	59.3	47.1	35.1	24.1	14.6	7.0	1.6	2.8
3	0.75	10.1	4.8	186.1	96.4	89.5	79.8	68.1	55.3	42.4	30.1	19.1	10.1	3.3	1.4	4.0
4	1.1	13.3	6.5	178.4	95.9	88.0	77.1	64.3	50.4	36.8	24.4	13.9	5.8	1.2	3.4	4.6
5	1.5	16.9	8.5	171.7	95.4	86.6	74.6	60.6	45.8	31.7	19.2	9.2	2.5	3.2	5.0	5.0

Supply with IEC 60725 source impedance ("weak supply"):

Model no. SP020-	Motor power (kW)	R.m.s. current (A)	Fundamental current (A)	THD (%)*	Harmonic order, magnitude as % fundamental											
					3	5	7	9	11	13	15	17	19	21	23	25
1	0.37	4.0	2.3	144.0	92.3	78.3	60.2	41.0	23.4	9.6	3.0	5.7	6.2	4.5	2.2	1.6
2	0.55	6.0	3.7	129.4	89.8	71.6	49.6	28.3	11.6	4.6	6.6	6.2	3.7	2.0	2.6	2.7
3	0.75	7.6	4.8	123.0	88.4	68.2	44.5	22.6	7.2	5.2	6.6	4.7	2.2	2.3	2.7	1.9
4	1.1	10.0	6.5	116.3	86.7	64.1	38.6	16.6	4.0	6.1	5.7	2.8	1.9	2.6	2.0	1.0
5	1.5	12.8	8.7	107.6	84.1	58.1	30.5	9.7	5.3	6.6	3.8	2.0	2.7	2.0	1.1	1.5

Digitax ST series

Supply with 5kA fault level:

Model no. DST 120-	Motor power (kW)	R.m.s. current (A)	Fundamental current (A)	THD (%)*	Harmonic order, magnitude as % fundamental											
					3	5	7	9	11	13	15	17	19	21	23	25
1	0.32	4.2	1.7	219.6	97.9	93.7	87.8	80.3	71.6	62.1	52.3	42.4	33.0	24.3	16.6	10.2
2	0.7	7.9	3.6	195.9	96.9	91.0	82.6	72.3	60.8	48.9	37.1	26.2	16.6	8.7	3.0	2.3
3	0.85	9.3	4.3	191.5	96.7	90.3	81.4	70.5	58.5	46.1	34.0	23.1	13.7	6.2	1.2	3.0
4	1.4	13.8	6.8	176.5	95.7	87.6	76.4	63.2	49.1	35.3	22.8	12.4	4.8	2.6	4.7	5.4

Supply with IEC 60725 source impedance ("weak supply"):

Model no. DST 120-	Motor power (kW)	R.m.s. current (A)	Fundamental current (A)	THD (%)*	Harmonic order, magnitude as % fundamental											
					3	5	7	9	11	13	15	17	19	21	23	25
1	0.32	3.1	1.7	150.6	93.2	80.7	64.2	46.2	29.0	14.6	4.8	4.6	6.5	6.0	4.0	1.9
2	0.7	6.0	3.6	129.5	89.8	71.7	49.8	28.4	11.7	4.6	6.6	6.2	3.7	2.0	2.6	2.7
3	0.85	7.0	4.4	125.3	88.9	69.5	46.4	24.7	8.7	4.8	6.7	5.3	2.6	2.1	2.7	2.2
4	1.4	10.5	7.0	112.7	85.7	61.6	35.2	13.6	4.7	6.8	5.2	2.3	2.5	2.6	1.6	1.2

Three phase 230V supply

SP0 series
Supply with 5kA fault level:

Model no. SP020-	Motor power (kW)	RMS current (A)	Fundamental current (A)	THD (%)*	Harmonic order, magnitude as % fundamental							
					5	7	11	13	17	19	23	25
1	0.37	2.8	1.3	186.5	95.3	90.8	78.1	70.4	53.6	45.0	28.7	21.4
2	0.55	4.1	2.1	170.2	93.8	87.8	71.7	62.2	42.5	33.1	16.8	10.5
3	0.75	5.2	2.7	163.8	93.0	86.4	68.7	58.5	37.7	28.1	12.2	6.7
4	1.1	6.8	3.6	157.1	92.2	84.8	65.3	54.3	32.5	22.8	7.9	3.9
5	1.5	8.6	4.9	147.4	90.6	81.9	59.5	47.3	24.6	15.4	4.7	5.1

Digitax ST series
Supply with 5kA fault level:

Model no. DST 120-	Motor power (kW)	RMS current (A)	Fundamental current (A)	THD (%)*	Harmonic order, magnitude as % fundamental							
					5	7	11	13	17	19	23	25
1	0.5	3.1	1.5	183.4	95.0	90.3	77.0	69.0	51.7	42.9	26.4	19.2
2	1.1	6.0	3.2	160.3	92.6	85.6	67.0	56.3	35.0	25.3	9.9	5.1
3	1.6	8.1	4.4	152.6	91.5	83.6	62.8	51.2	28.9	19.3	5.3	3.0
4	2.2	10.7	6.2	142.0	89.7	80.2	56.1	43.3	20.3	11.6	4.3	5.6

Three phase 400V supply

SP0 series
Supply with 5kA fault level:

Model no. SP040-	Motor power (kW)	RMS current (A)	Fundamental current (A)	THD (%)*	Harmonic order, magnitude as % fundamental							
					5	7	11	13	17	19	23	25
1	0.37	1.7	0.7	203.1	96.4	92.9	83.0	76.8	62.8	55.4	40.5	33.3
2	0.55	2.6	1.2	190.9	95.6	91.4	79.5	72.3	56.3	48.0	32.0	24.6
3	0.75	3.3	1.6	184.3	95.1	90.4	77.4	69.5	52.3	43.6	27.1	19.8
4	1.1	4.3	2.1	177.2	94.5	89.2	74.7	66.1	47.7	38.6	21.9	14.9
5	1.5	5.6	2.8	170.3	93.8	87.9	71.8	62.4	42.8	33.4	17.0	10.5

Digitax ST series
Supply with 5kA fault level:

Model no. DST 040-	Motor power (kW)	RMS current (A)	Fundamental current (A)	THD (%)*	Harmonic order, magnitude as % fundamental							
					5	7	11	13	17	19	23	25
1	0.75	2.8	1.3	188.8	95.5	91.1	78.9	71.4	55.0	46.6	30.4	23.0
2	1.4	4.5	2.2	175.8	94.4	89.0	74.2	65.4	46.7	37.5	20.9	13.9
3	2.0	6.4	3.3	166.5	93.4	87.1	70.1	60.3	40.1	30.6	14.6	8.6
4	3.0	8.8	4.8	152.7	89.6	81.1	62.6	53.3	34.1	24.5	9.2	5.9
5	4.0	10.7	6.5	131.2	79.7	66.5	51.4	47.2	31.6	21.1	6.6	6.3

Input line reactors (line chokes)

Where necessary, a reduction in harmonic current levels can be obtained by fitting reactors in the input supply lines to the drive. This also gives increased immunity from supply disturbances such as voltage surges caused by the switching of high-current loads or power-factor correction capacitors on the same supply circuit. The following table shows the corresponding harmonics where reactors are fitted in the supply lines. Standard parts are available from Control Techniques with the following part numbers:

Single phase 230V:		
Inductance (mH)	Rated current (A)	Part number
0.5	26	4402-0226
1.0	15	4402-0225
2.25	6.5	4402-0224

Three phase 230V & 400V:		
Inductance (mH)	Rated current (A)	Part number
1.0	15.4	4402-0228
2.0	7.9	4402-0227

To avoid excessive voltage drop at full load the values used should not exceed 2% per-unit. Reactor current ratings must be at least equal to the r.m.s. values shown, and peak current rating (to avoid magnetic saturation) should be twice that value.

Single phase 230V supply

SP0 series

Supply with 5kA fault level:

Model no. SP 020-	Motor power (kW)	L (mH)	R.m.s. current (A)	Fundamental current (A)	THD (%)*	Harmonic order, magnitude as % fundamental												
						3	5	7	9	11	13	15	17	19	21	23	25	
1	0.37	2	3.6	2.3	121.2	87.8	66.8	42.7	21.5	8.8	7.2	6.9	4.6	3.0	3.0	2.7	1.9	
2	0.55	1	5.9	3.6	127.4	89.2	70.3	47.8	26.9	11.9	7.0	7.4	6.0	3.7	2.9	3.0	2.5	
3	0.75	1	7.5	4.7	121.8	87.9	67.1	43.2	22.0	8.9	7.0	6.9	4.7	2.9	3.0	2.7	1.9	
4	1.1	1	9.7	6.4	116.0	86.4	63.5	38.0	17.1	7.0	7.1	5.8	3.4	2.8	2.8	2.0	1.5	
5	1.5	0.5	13.4	8.5	123.2	88.3	68.0	44.5	23.2	9.2	6.5	6.8	4.8	2.9	2.8	2.7	2.0	

Digitax ST series

Supply with 5kA fault level:

Model no. DST 120-	Motor power (kW)	L (mH)	R.m.s. current (A)	Fundamental current (A)	THD (%)*	Harmonic order, magnitude as % fundamental												
						3	5	7	9	11	13	15	17	19	21	23	25	
1	0.32	2	2.8	1.7	127.9	89.4	70.8	48.3	26.8	10.7	5.7	7.4	6.3	3.5	2.2	3.0	2.8	
2	0.7	1	5.8	3.6	127.6	89.2	70.4	48.0	27.0	12.0	7.0	7.4	6.0	3.7	2.9	3.0	2.5	
3	0.85	1	6.8	4.3	123.9	88.4	68.3	45.0	23.8	9.9	7.0	7.1	5.2	3.2	3.0	2.9	2.1	
4	1.4	1	10.3	6.9	111.7	85.2	60.6	34.3	14.2	7.2	7.4	5.2	3.1	3.1	2.6	1.8	1.7	

Three phase 400V supply

SP0 series

Supply with 5kA fault level:

Model no. SP040-	Motor power (kW)	L (mH)	RMS current (A)	Fundamental current (A)	THD (%)*	Harmonic order, magnitude as % fundamental							
						5	7	11	13	17	19	23	25
1	0.37	2	1.2	0.8	117.0	83.3	68.7	36.3	22.2	7.4	7.7	6.6	4.7
2	0.55	2	1.8	1.2	106.0	79.4	62.2	26.8	13.8	7.5	7.6	3.9	2.9
3	0.75	2	2.2	1.6	100.0	76.9	58.1	21.6	10.1	7.6	6.7	3.0	3.0
4	1.1	2	2.9	2.1	93.5	73.9	53.3	16.4	7.5	7.2	5.2	2.9	3.1
5	1.5	2	3.8	2.8	87.2	70.7	48.4	11.8	6.6	6.1	3.7	3.0	2.6

* Total Harmonic Distortion, expressed as percentage of fundamental

Model no. SP040-	Motor power (kW)	L (mH)	RMS current (A)	Fundamental current (A)	THD (%)*	Harmonic order, magnitude as % fundamental							
						5	7	11	13	17	19	23	25
1	0.75	2	1.9	1.3	104.0	78.6	60.9	25.1	12.5	7.6	7.3	3.5	2.9
2	1.4	2	3.1	2.2	92.2	73.3	52.3	15.4	7.2	7.0	4.9	2.9	3.1
3	2.0	2	4.3	3.3	83.9	68.9	45.7	9.9	6.6	5.3	3.0	3.0	2.2
4	3.0	2	6.1	4.8	75.7	64.1	38.8	6.6	6.9	3.4	2.7	2.1	1.4
5	4.0	1	8.6	6.4	88.3	71.5	49.6	12.0	4.8	5.6	3.3	2.5	2.4

* Total Harmonic Distortion, expressed as percentage of fundamental

Further measures for reducing harmonics

It is unusual for harmonics to pose a problem unless a substantial part (e.g. over 50%) of the supply system capacity is accounted for by drives or other power electronic loads. In such cases it is usually most cost-effective to analyse a complete installation for harmonic current or voltage and to apply remedial measures such as harmonic filters, if necessary, for the entire installation at the common supply point. Harmonic currents from drives add approximately arithmetically.

CONDUCTED RADIO FREQUENCY EMISSION

Radio frequency emission in the range from 150kHz to 30MHz is generated by the switching action of the main power devices (IGBTs) and is mainly conducted out of the equipment through electrical power wiring. It is essential for compliance with the emission standards that the recommended filter and a shielded (screened) motor cable should be used. Most types of cable can be used provided it has an overall screen, which is continuous for its entire length. For example the screen formed by the armouring of steel wire armoured cable is acceptable. The capacitance of the cable forms a load on the drive and filter, and should be kept to a minimum. Compliance tests were done with cable having a capacitance between the three power cores and the screen of 412pF per metre (measured at 1kHz), which is typical of steel wire armoured cable. In addition to motor cable length, conducted emission will also vary with drive switching frequency: selecting the lowest switching frequency will produce the lowest level of emission. In order to meet the stated standards the drive, filter and motor cable must be installed correctly. Wiring guidelines are given later.

The drive contains a cost-effective internal input filter which gives a reduction of about 30dB in the level of emission at the supply terminals. It provides compliance with EN 61800-3 for the second environment, unrestricted distribution, for motor cable lengths not exceeding 12m (200V) or 14m (400V).

Unlike a conventional filter, the internal filter continues to provide this attenuation with a long motor cable. For practical purposes, this filter in conjunction with a screened motor cable is sufficient to prevent the drive from causing interference to most good-quality industrial equipment.

It is recommended that the filter be used in any situation unless the earth leakage current, which is up to 12mA¹, is unacceptable. The Installation Guide gives instructions on how to remove and replace it.

For applications where there are stricter requirements for radio frequency emission, e.g. to the generic standards EN 61000-6-4 etc. or the first environment in EN 61800-3, the optional external filter must be used.

The tables summarise the performance of all filters.

200V drives (single phase and three phase):

Motor cable length (m)	Switching frequency (kHz)					
	3	4	6	8	12	16
Using internal filter:						
0 – 7	E2U					TBA
7 – 9	E2U			E2R		TBA
9 – 11	E2U		E2R			TBA
>11	E2R					TBA
Using external filter:						
0 – 20	R			I		
20 – 100	I					

400V drives:

Motor cable length (m)	Switching frequency (kHz)					
	3	4	6	8	12	16
Using internal filter:						
0 - 6	E2U			E2R		TBA
6 - 12	E2U		E2R			TBA
12 - 14	E2U	E2R				TBA
>14	E2R					TBA
Using external filter:						
0 – 20	R			I		
20 – 70	I					
>70 - 100	I	- do not use -				

¹ Worst case for 400V 50Hz supply

Key to table

The requirements are listed in descending order of severity, so that if a particular requirement is met then all requirements listed after it are also met.

Code	Standard	Description	Frequency range	Limits	Application
R	EN 61000-6-3 IEC 61000-6-3 EN 50081-1	Residential: Generic emission standard for the residential commercial and light - industrial environment	0.15 - 0.5MHz	66-56dB μ V quasi peak 56-46dB μ V average	AC supply lines
			0.5 - 5MHz	56dB μ V quasi peak 46dB μ V average	
			5 - 30MHz	60dB μ V quasi peak 50dB μ V average	
	EN 61800-3 IEC 61800-3	Product standard for adjustable speed power drive systems	Requirements for the first environment ¹ : unrestricted distribution (category C1)		
I	EN 61000-6-4 IEC 61000-6-4 EN 50081-2	Industrial: Generic emission standard for the industrial environment	0.15 – 0.5MHz	79dB μ V quasi peak 66dB μ V average	AC supply lines
			0.5 –30MHz	73dB μ V quasi peak 60dB μ V average	
	EN 61800-3 IEC 61800-3	Product standard for adjustable speed power drive systems	- Requirements for the first environment ¹ : restricted distribution ² (category C2)		
E2U	EN 61800-3 IEC 61800-3	Product standard for adjustable speed power drive systems	- Requirements for the second environment: unrestricted distribution (category C3)		
E2R	EN 61800-3 IEC 61800-3	Product standard for adjustable speed power drive systems	- Requirements for the second environment: restricted distribution (category C4)		
¹	The first environment is one where the low voltage supply network also supplies domestic premises				
²	When distribution is restricted, drives are available only to installers with EMC competence				

- Caution -

This caution applies where the drive is used in the first environment with restricted distribution according to EN 61800-3.

This is a product of the restricted distribution class according to IEC 61800-3. In a domestic environment this product may cause radio interference in which case the user may be required to take adequate measures.

Notes

- Where the drive is incorporated into a system with rated input current exceeding 100A, the higher emission limits of EN 61800-3 for the second environment are applicable, and no filter is then required.
- Operation without a filter is a practical cost-effective possibility in an industrial installation where existing levels of electrical noise are likely to be high, and any electronic equipment in operation has been designed for such an environment. This is in accordance with EN 61800-3 in the second environment, with restricted distribution. There is some risk of disturbance to other equipment, and in this case the user and supplier of the drive system must jointly take responsibility for correcting any problem which occurs.

Recommended external filters - Dual footprint/bookcase format

Supply voltage	Control Techniques part number	
	Manufacturer Schaffner	Manufacturer Epcos
230V single phase	4200-6000	TBA
230V three phase	4200-6001	TBA
400/480V three phase	4200-6002	TBA

- WARNING -

These filters and the internal filter have earth leakage current exceeding 3.5mA. A permanent fixed earth connection is necessary to avoid electrical shock hazard. Further precautions, such as a supplementary earth connection or earth monitoring system, may also be required.

Typical conducted emission test data

The conducted emission from a SP0405 operating with filter part number 4200-6002, at 3kHz switching frequency with 100m motor cable, is shown in the emission plot in Figure 11. (For conducted emission purposes the SP0 and DST1 drives are identical.)

Note on ungrounded supply systems (IT systems)

Care is needed when using inverter drives with RFI filters on ungrounded supply systems. The filters must be designed to operate with an earth fault on the supply. In some cases damage may occur to filters if an earth fault occurs in the driven motor, as the drive may not trip.

For Unidrive SP size 0 and Digitax ST, both internal and external filters have been designed for use with IT supplies. An earth fault on the supply will have no effect.

The table shows the requirements for combinations of drive type and filter.

Filter	200V drives (1 & 3 phase)	400V drives
None	Permitted. Runs with motor earth fault.	Permitted. Runs with motor earth fault.
Internal only	Not permitted unless separate motor earth fault protection is fitted.	Permitted. Trips on motor earth fault.
External	Permitted. Trips on motor earth fault.	Permitted. Trips on motor earth fault.

Note on shared external filters for multiple drives

When more than one drive is used in the same enclosure, some cost saving is possible by sharing a single filter of suitable current rating between several drives. Tests have shown that combinations of drives with a single filter are able to meet the same emission standard as a single drive, provided that all filters and drives are mounted on the same metal plate. Because of the unpredictable effect of the additional wiring and the need for separate fuses for the drives on the drive side of the filter, this arrangement is not recommended where strict compliance with a specific standard is required, unless emission tests can be carried out.

Related product standards

The conducted emission levels specified in the generic emission standards are equivalent to the levels required by the following product specific standards:

Conducted emission from 150kHz to 30MHz		
Generic standard	Product standard	
EN 61000-6-3 EN 50081-1	EN 55011 Class B CISPR 11 Class B	Industrial, scientific and medical equipment
	EN 55014 CISPR 14	Household electrical appliances
	EN 55022 Class B CISPR 22 Class B	Information technology equipment
EN 61000-6-4 EN 50081-2	EN 55011 Class A Group 1 CISPR 11 Class A Group 1	Industrial, scientific and medical equipment
	EN 55022 Class A CISPR 22 Class A	Information technology equipment

RADIATED EMISSION

When installed in a standard metal enclosure according to the wiring guidelines, the drive will meet the radiated emission limits required by the generic industrial emission standard EN 61000-6-4 (previously EN 50081-2).

Important note

Compliance was achieved in tests using representative enclosures and following the guidelines given. No special EMC techniques were used beyond those described here. Every effort was made to ensure that the arrangements were robust enough to be effective despite the normal variations which will occur in practical installations. However no warranty is given that installations built according to these guidelines will necessarily meet the same emission limits.

The limits for emission required by the generic emission standards are summarised in the following table:

Radiated emission from 30 to 1000MHz				
Standard	Application	Frequency range	Limits	Comments
EN 61000-6-3	Enclosure	30 - 230MHz	30dB μ V/m quasi peak at 10m	
		230 - 1000MHz	37dB μ V/m quasi peak at 10m	
EN 61000-6-4	Enclosure	30 - 230MHz	40dB μ V/m quasi peak at 10m	Standard specifies limits of 30 and 37dB μ V/m respectively at a measuring distance of 30m; emission may be measured at 10m if limits are increased by 10dB
		230 - 1000MHz	47dB μ V/m quasi peak at 10m	

EN 61800-3 (IEC 61800-3) requires the following, in order of increasing emission level:

As EN 61000-6-3	First environment - unrestricted distribution
As EN 61000-6-4	First environment - restricted distribution
30 – 230MHz 40dB μ V/m at 30m 230 – 1000MHz 50dB μ V/m at 30m	Second environment – unrestricted distribution

Test Data

The test data is based on radiated emission measurements made in a standard steel enclosure containing a single DST1405 drive, in a calibrated open area test site. Details of the test arrangement are described:

A standard Rittal steel enclosure was used having dimensions 1900mm (high) \times 600mm (wide) \times 500mm (deep). Two ventilation grilles, both 200mm square, were provided on the upper and lower faces of the door. No special EMC features were incorporated.

The drive and recommended RFI input filter were fitted to the internal back-plate of the enclosure, the filter casing making electrical contact with the back-plate by the fixing screws. Standard unscreened power cable was used to connect the cubicle to the supply.

A Unimotor 115UMC600CSJFE permanent magnet servomotor was connected by 3m of shielded cable (steel braided - type SY) and mounted externally. The motor screen was not bonded to the enclosure wall at the point of entry.

A full complement of option modules was fitted. A 2m screened control cable was connected to the drive control terminals, and the screen of this cable was tied to the grounding bracket in accordance with the instructions in the installation guide (repeated here in WIRING GUIDELINES).

The drive was operated at 460 rev/min, with a switching frequency of 12kHz which is the worst case for RF emission.

No additional EMC preventative measures were taken, e.g. RFI gaskets around the cubicle doors.

The following table summarises the results for radiated emission, showing the six highest measurements over the frequency range 30 to 1000 MHz:

Frequency MHz	Emission dB μ V/m	Level required by industrial standard EN 61000-6-4 at 10m
38.95	31.9	40
39.15	32.0	40
39.35	32.2	40
39.6	32.0	40
40.2	31.0	40
40.95	32.2	40

The results show that the limit for the industrial emission standard is met with a margin of at least 7.8dB. The limit for EN 61800-3 (IEC 61800-3) is met for the first environment with restricted distribution, and for the second environment without restriction.

Enclosure construction

For most installations the enclosure will have a back-plate which will be used to mount variable speed drive modules, RFI filters and ancillary equipment. This back-plate can be used as the EMC earth plane, so that all metal parts of these items and cable screens are fixed directly to it. Its surface should have a conductive protective surface treatment such as zinc plate. If it is painted then paint will have to be removed at the points of contact to ensure a low-inductance earth connection which is effective at high frequency.

The motor cable screen must be clamped to the drive grounding clamp. It may also be bonded at the point of exit, through the normal gland fixings.

Depending on construction, the enclosure wall used for cable entry might have separate panels and have a poor connection with the remaining structure at high frequencies. If the motor cable is only bonded to these surfaces and not to a back-plate, then the enclosure may provide insufficient attenuation of RF emission. The use of the purpose-designed drive grounding clamp is strongly recommended.

It is the bonding to a common metal plate which minimises radiated emission. There is no need for a special EMC enclosure with gaskets etc. In the tests described, opening the cubicle door had little effect on the emission level, showing that the enclosure itself does not provide significant screening.

Related product standards

The radiated emission levels specified in EN 61000-6-4 are equivalent to the levels required by the following product standards:

Radiated emission from 30 to 1000MHz		
Generic standard	Product standard	
EN 61000-6-4	CISPR 11 Class A Group 1	Industrial, scientific and medical equipment
	CISPR 11 Class A Group 1	
	EN 55022 Class A	Information technology equipment
CISPR 22 Class A		

The wiring guidelines on the following pages should be observed to achieve minimum radio frequency emission. The details of individual installations may vary, but aspects which are indicated in the guidelines as important for EMC must be adhered to closely.

The guidelines do not preclude the application of more extensive measures which may be preferred by some installers. For example, the use of full 360° ground terminations on shielded cables in the place of 'pig-tail' ground connections is beneficial, but is not necessary unless specifically stated in the instructions.

1. If the filter is not used in the "footprint" mode, then the drive and filter must be mounted on the same metal back-plate, and their mounting surfaces must make a good direct electrical connection to it. The use of a plain metal back-plate (eg galvanised not painted) is beneficial for ensuring this without having to scrape off paint and other insulating finishes.
2. The filter must be mounted close to the drive so that its connecting wires can be directly connected. The wires must not be extended.
3. A shielded (screened) or steel wire armoured cable must be used to connect the drive to motor. The shield must be bonded to the drive using the grounding clamp provided.
4. The AC supply connections must be kept at least 4in (100mm) from the drive, motor cable and braking resistor cable.

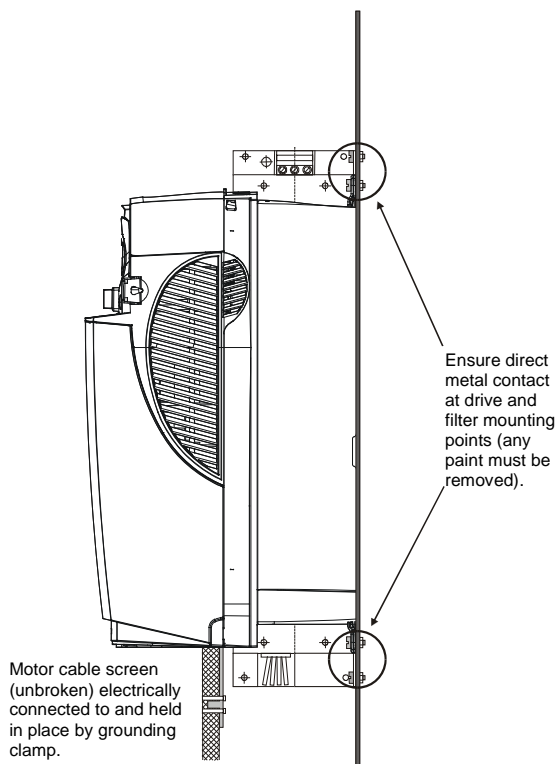

Figure 3: Grounding the drive, filter and motor cable screen

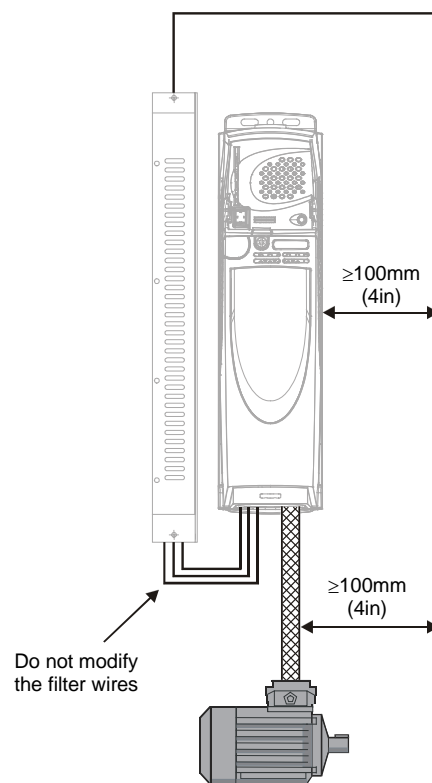

Figure 4: Input wiring spacing

5. Connect the shield of the motor cable to the ground terminal of the motor frame using a link that is as short as possible and not exceeding 50mm (2 in) in length. A full 360° termination of the shield to the motor terminal housing (if metal) is beneficial.

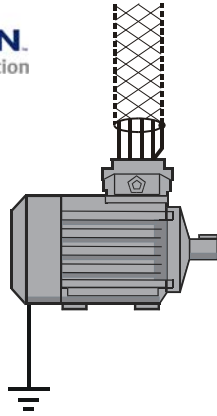

Figure 5: Connecting the motor cable shield at the motor

6. If an additional safety earth wire is required for the motor, it can either be carried inside or outside the motor cable shield. If it is carried inside then it must be terminated at both ends as close as possible to the point where the screen is terminated. It must always return to the drive and not to any other earth circuit.
7. Wiring to the braking resistor should be shielded. The shield must be bonded to the back-plate using an uninsulated metal cable-clamp. It need only be connected at the drive end.
8. If the braking resistor is outside the enclosure then it should be surrounded by an earthed metal shield.

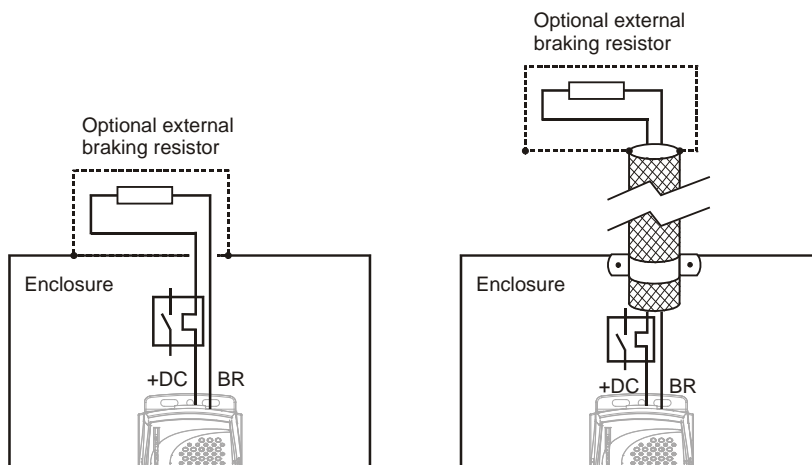

Figure 6: Screening of braking circuit

9. Signal and control wiring must be kept at least 12in (300mm) from the drive and motor cable.

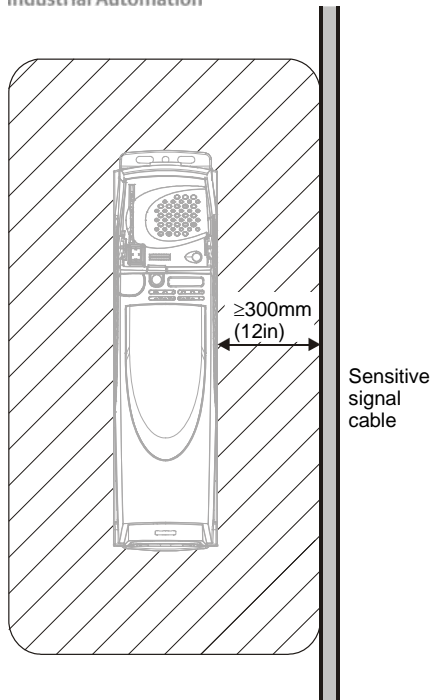

Figure 7: Signal wiring spacing

10. The control wiring “0V” connection should be earthed at one point only, preferably at the controller and not at a drive.

Variations to wiring guidelines

– Output ferrite ring

If a ferrite ring is to be used to further reduce conducted emission, it should be mounted close to the drive, and the output power conductors (U,V,W but not E) should be passed once through the central aperture, all together in the same direction.

– If drive control wiring leaves the enclosure

This includes all control, encoder and option module wiring but not the status relay circuit or the serial port. One of the following additional measures must be taken:

- Use shielded cables (one overall shield or separate shielded cables) and clamp the shield(s) to the grounding bracket provided, as shown in Figure 8.

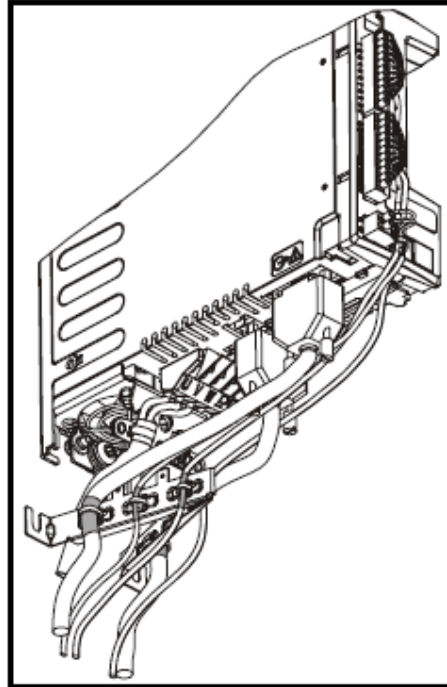

Grounding bracket and drive to be directly connected to a grounded backplate.

Figure 8: Earthing of signal cable screens using the grounding bracket

or:

- Pass the control wires through a ferrite ring part number 3225-1004. More than one cable can pass through a ring. Ensure the length of cable between the ring and drive does not exceed 125mm (5in).

– **Interruptions to the motor cable**

The motor cable should ideally be a single run of shielded cable having no interruptions. In some situations it may be necessary to interrupt the cable, for example to connect the motor cable to a terminal block within the drive enclosure, or to fit an isolator switch to allow safe working on the motor. In these cases the following guidelines should be observed. The most important factor is always to minimise the inductance of the connection between the cable shields.

– **Terminal block within enclosure**

The motor cable shields should be bonded to the back-plate using uninsulated cable-clamps which should be positioned as close as possible to the terminal block. Keep the length of power conductors to a minimum and ensure that all sensitive equipment and circuits are at least 0.3m (12 in) away from the terminal block.

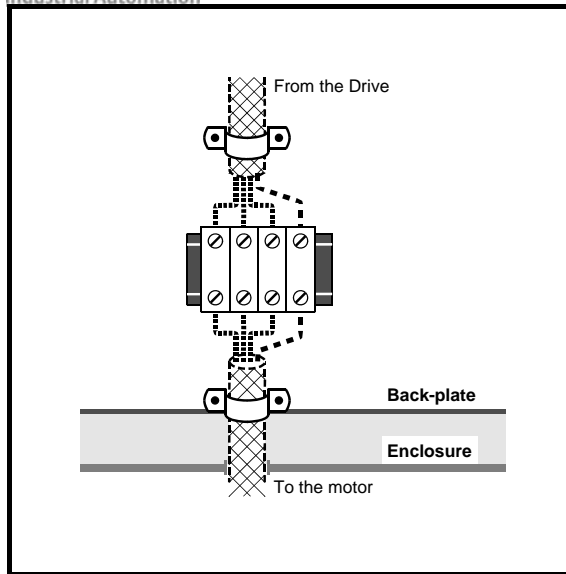

Figure 9: Connecting the motor cable to a terminal block in the enclosure

– **Using a motor isolator switch**

The motor cable shields should be connected by a very short conductor having a low inductance. The use of a flat metal bar is recommended; conventional wire is not suitable. The shields should be bonded directly to the coupling bar using uninsulated metal cable-clamps. Keep the length of power conductors to a minimum and ensure that all sensitive equipment and circuits are at least 0.3m (12 in) away. The coupling bar may be grounded to a known low impedance ground nearby, for example a large metallic structure which is connected closely to the drive ground.

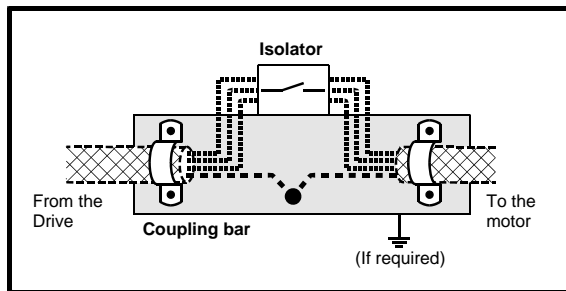

Figure 10: Connecting the motor cable to an isolating switch

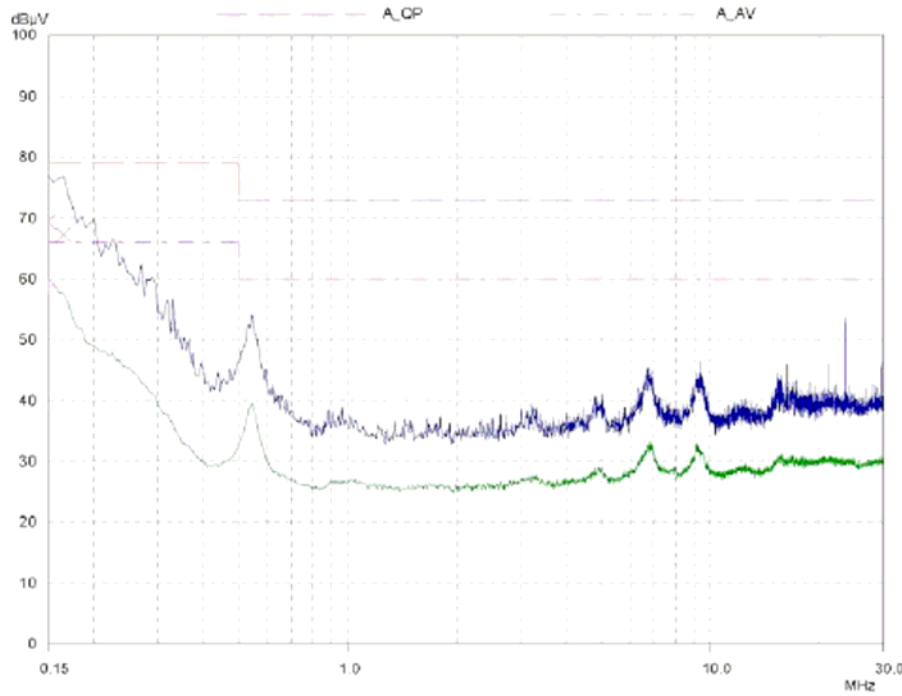

Figure 11: Example conducted emission plot (SP0405, 100m cable, 3kHz switching frequency)